

Engineering Guideline

pac-Carriers Type 9195

Universal



Integration of conventional process automation interfaces - pac Carrier

The pac carrier reflects the intention of R. STAHL to provide state-of-the-art concepts tailored to the needs of process automation and machine manufacturing. It is designed to reduce the cost of installation by space saving compact design and simplified installation. The Ex i/l.S. isolators can be mounted without the need for a tool. The intrinsically safe signal is directly connected to the modules by means of two different types of detachable connectors - screw type or cage clamp type.

The connection to the control system I/O module is simply done by connecting a customer specific cable to the screw terminal of the pac Carrier.

The use of the pac Carrier reduces the required time for installation and enables pre-wiring for later upgrades.

Your benefits:

- The most flexible system for the integration of Ex i/l.S. signals
- Complete line fault transparency - no blind spots
- Compact and rugged installation
- Pre-wiring enables easy and fault proved upgrade
- Systems for installation in hazardous location for the control system and Ex i/l.S. isolation made by STAHL

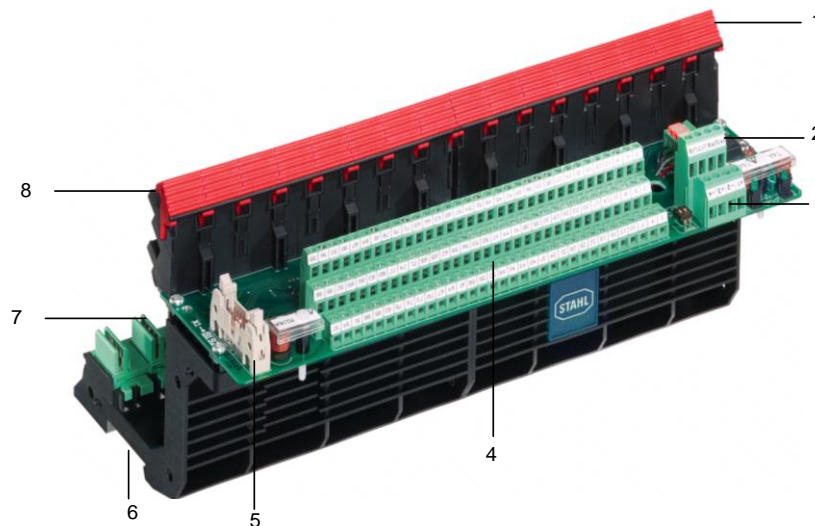

Example of 16 Slots Carrier

1. Ejector mechanism
2. Redundant and fused supply
3. Power supply failure and line fault signaling via relay contact
4. Interface for field signal connection w/o Ex i/l.S. isolator
5. Connector for HART Multiplexer type 9192/32
6. Installation on DIN rail or mounting plate
7. Integrated pac bus for power supply and line-fault signaling
8. Reliable snap-in mechanism, without tool

HART-Multiplexer Type 9192

Basic function: multiplexer for HART field devices, 32 channels. The HART-Multiplexer type 9192 is used for digital connection of up to 32 HART-capable field devices, such as transmitters and regulating valves, to a PC. The PC communicates with the HART-Multiplexer via an RS 485 bus. The software PDM allows configuration and diagnostics of all connected HART-capable field devices, plus continuous documentation of the process variables and status.

Interconnection:

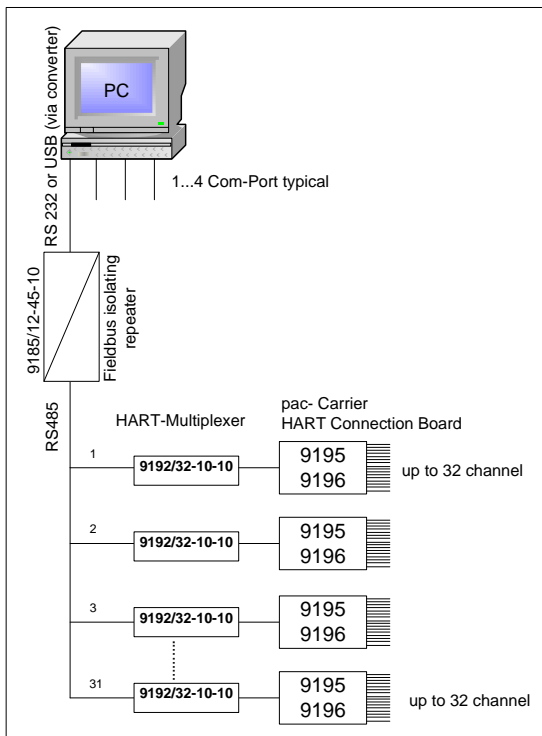

Accessories and Spare Parts		
Designation	Description	Order number
Fieldbus isolating repeater	<ul style="list-style-type: none"> Adjustable baud rate (1.2 kBit/s up to 1.5 MBit/s) Power supply 24 V AC/DC 	9185/12-45-10s
pac-Carrier	8 slots, HART	9195/08H-....-...
	16 slots, HART	9195/16H-....-...
Connection board	for none Ex-applications, HART, 16 channels	9196/16H-XX0-...



Daisy chaining of several pac- Carriers to one HART-Multiplexer:

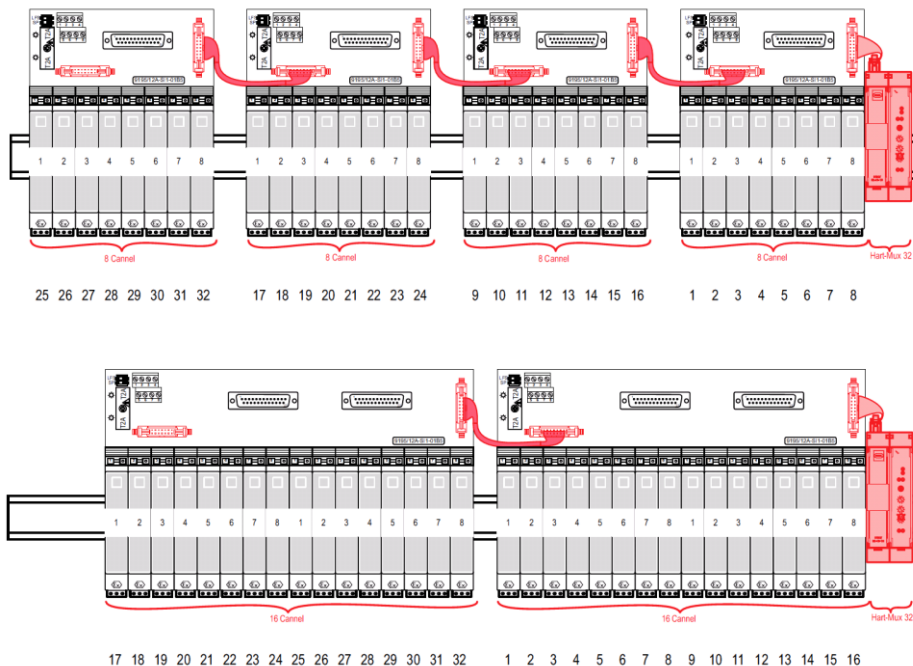

Line fault detection alarms

- For one pac- Carrier

LFD is routed to terminal 7 and 8 on the pac- Carrier (switch LFS OFF).

	Single channel module	Dual channel module
Pac- Carrier	9195/21A-S11-0.B.	9195/12A-S11-0.B.
Connection diagram		
Note	Here can be used all channels of the pac- Carrier.	

- For several pac- Carriers

These are routed to terminal 7 on the first pac- Carrier and to terminal 8 on the last pac- Carrier.

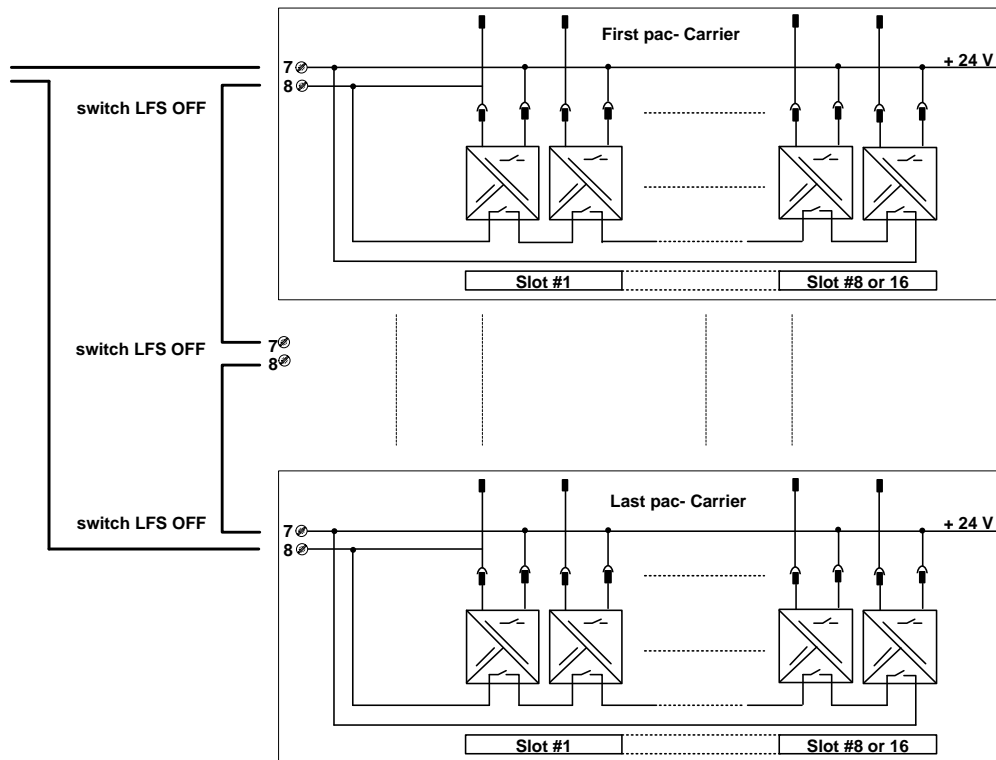

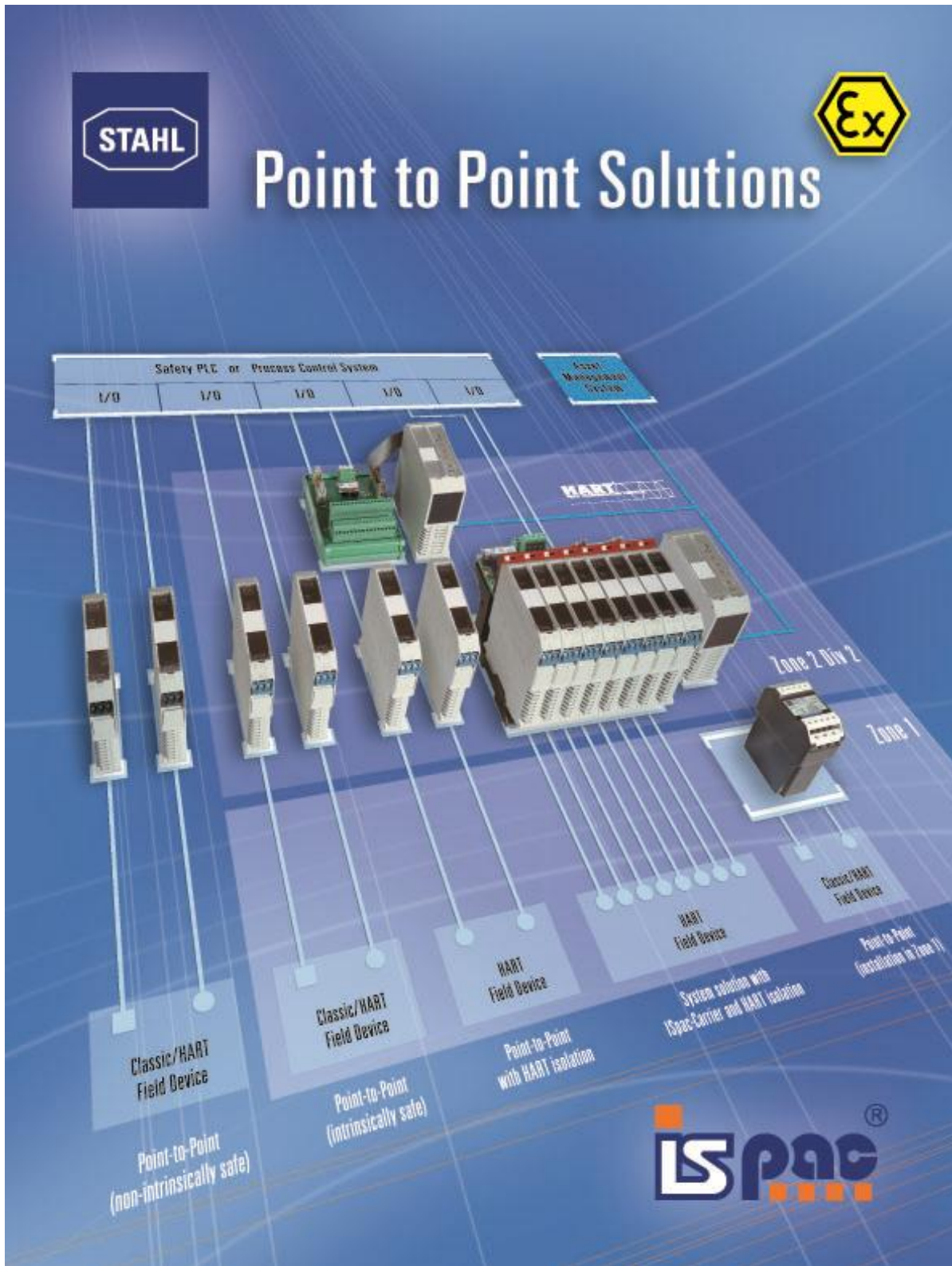

Content

Control system		pac-Carrier					
Signal type	Channels	Slots	Stahl cable type	HART-MUX	pac-Carrier type	ISpac	page
DI, DO, AI AO	32	16	without	NO	9195/16A-XX0-01C	ALL	7-12
				9192/32	9195/16H-XX0-01C		13-17
AI	16	8	9195/C-009	NO	9195/08A-XX0-03A5	9160/23-10-11	18-22
AO						9182/20-59-11	
DI	32	16	9195/C-009	NO	9195/16A-XX0-03B3	9165/26-11-11	23-28
DO						9170/20-10-11	
						9175/20-1X-11	
						9176/20-1X-00	

**pac-Carrier
Type 9195/16A-XX0-01C**

- Signal types: AI / AO / DI / DO
- pac-Carrier for 16 modules, up to 32 signals
- all ISpac isolators can be mounted
- Redundant power supply with fault signalization contact and exchangeable fuses
- Horizontal or vertical installation
- Simple installation on DIN rail or mounting plate
- Many labeling possibilities
- Fast and secure installation of the isolators without tools
- Comfortable exchange of the isolators with secured ejector mechanism
- Installation possible in Zone 2, Zone 22 (non conductible dust) and Div. 2

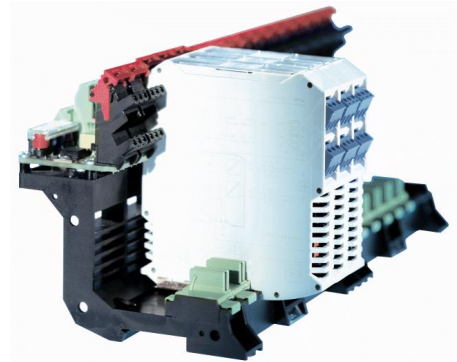

05179E00

Comfortable and simple integration of the Ex i/I.S. isolators ISpac. Flexible wiring possibilities on the system side with screw terminals.

System overview

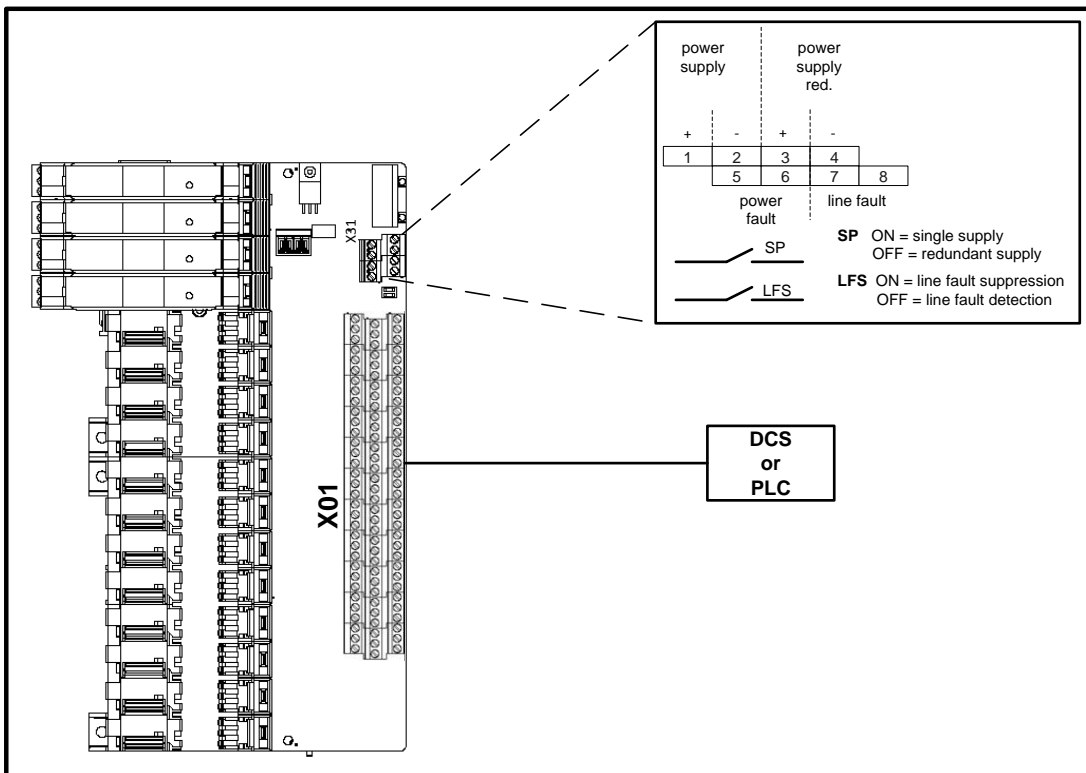

Selection table

Control system			pac-Carrier			
DCS manufacturer	DCS type	I/O-cards type	Slots	HART-MUX	Redundancy	Type
all	all	AI / AO/ DI / DO	16	no	no	9195/16A-XX0-01C

Technical data

Certificates	BVS 03 ATEX E213 X
Explosion protection	⊕ II 3 G Ex nA nC II T4
Installation	In Zone 2, Zone 22 (non conductible dust), Div. 2 and in the safe area
Power supply	(X31)
Nominal voltage U_N	24 V DC (19 V ... 31,2 V)
Redundant supply	yes, decoupled with diodes
Indication	2 LED green „PWR1“; „PWR2“
Fuse	2 x TR5; T 2,0 A; exchangeable, for primary and redundant supply
Polarity reversal protection	yes
Connection field devices	
Connection	at the terminals of the Exi/I.S. isolators (see "signal loops")
Number of channels	32
Connection automation system	(X01)
Connection	Customer specific cable
Number of channels	up to 32
Error messaging	(X31)
Power supply failure PF	Contact (35 V / 100 mA), closed in good conditions
Line fault LF (of ISpac modules)	Contact (35 V / 100 mA), closed in good conditions
Setting switch „SP“	Power failure message suppressed for redundant supply (single supply)
Setting switch „LFS“	Line fault message suppressed
Ambient conditions	
Ambient temperature	max. - 20 °C ... + 70 °C (see specification of the Ex i/I.S. isolators)
Storage temperature	- 40 °C ... + 80 °C
Relative humidity (no condensation)	≤95 %
Mechanical data	
Weight	approx. 320 g
Mounting type	on DIN rail or mounting plate (4 x screw M6)
Mounting position	horizontal or vertical
Casing / Terminal protection class	IP 00 / IP 20
Casing material	PA 6.6
Fire protecting class (UL-94)	V0

Signal loops

The diagrams below show typical applications. Please refer to the connection list to get the entire connection scheme. Basic technical parameters of the ISpac isolating repeaters can be found at the end of this document. The detailed specifications can be downloaded at: www.ispac.info.

We offer for types 9146, 9162 und 9182 compact trip amplifier with 2 configurable limit values

Frequency transmitter

The frequency transmitter allows to monitor the speed of rotating devices in the hazardous area

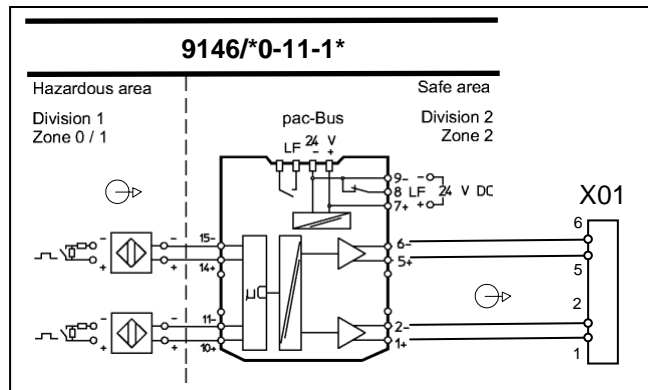

Transmitter supply unit (AI)

for 2-, 3-wire transmitter and mA sources
for 2-wire transmitter with HART

Alternative: Loop powered type 9162 and 9163

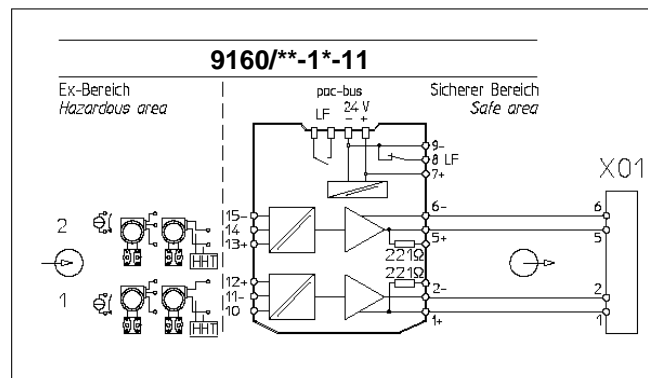

Isolating repeater (AO)

for control valves, i/p-converters or indicators
bi-directional HART communication

Alternative: Loop powered type 9167

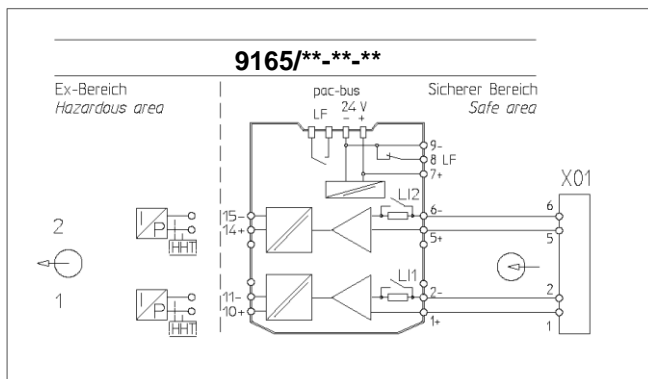

Switching repeater (DI)

for NAMUR proximity switches and contacts

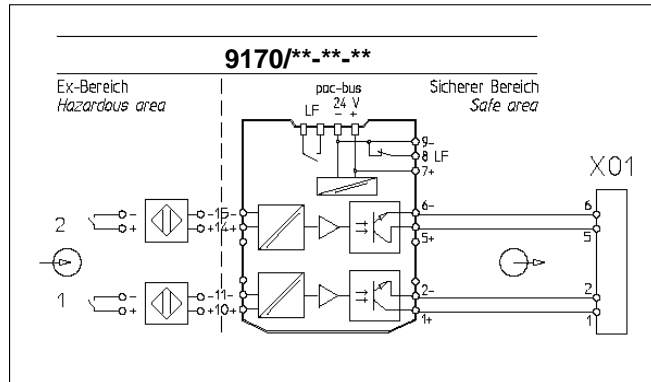

Digital output (DO)

for solenoid valves and indicators

Alternative: Loop powered type 9176

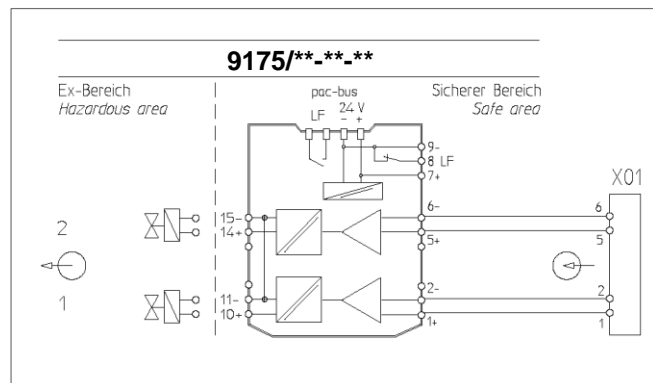

Temperature transmitter (AI)

for resistance thermometer, thermocouple and RTD (Configuration by means of DIP switches or ISpac Wizard software)

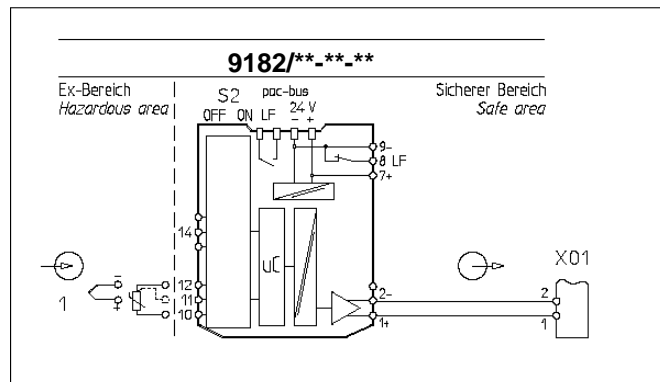

*) Suitable for 4-wire (Pins: 10, 11, 12, and 14).
The connection of two sensors in 4-wire scheme requires an additional external terminal.



Accessories and Spare Parts

Designation	Illustration	Description	Order number
Non-Ex i Termination Module	 <p>06314E00</p>	The termination module is used to integrate non-Ex i field circuit into the system integration solution pac-Carrier type 9195. In such a way it enables a flexible mixture of Ex i and non-Ex i field circuits.	9191/20-00-50s

Dimension drawings (all dimensions in mm) - subject to alterations

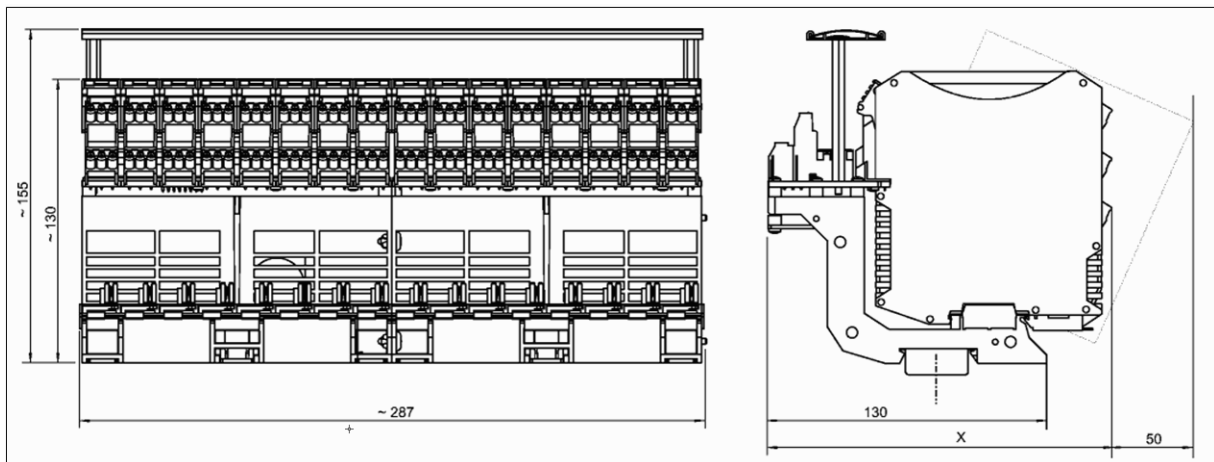

12472E00

	Dimension x
Screw terminals	176 mm
Cage clamp terminals	186 mm

Please note: In order to snap in the ISpac modules an extra space of approx. 50 mm is required. Please read the "ISpac engineering guideline" carefully before you start to engineer the enclosures with incorporated ISpac modules with or without pac-Carriers. The "ISpac engineering guideline" can be downloaded from: www.ispac.info.



Connection list

Connection to field devices (Ex i / I.S.)

notes	i.s terminal module	slot no.	terminal module	terminal X 01	notes	i.s terminal module	slot no.	terminal module	terminal X 01
*1	10	1	1	1	*1	10	9	1	49
	11		2	2		2		50	
	12		3	3		3		51	
	13		4	4		4		52	
	14		5	5		5		53	
	15		6	6		6		54	
*1	10	2	1	7	*1	10	10	1	55
	11		2	8		2		56	
	12		3	9		3		57	
	13		4	10		4		58	
	14		5	11		5		59	
	15		6	12		6		60	
*1	10	3	1	13	*1	10	11	1	61
	11		2	14		2		62	
	12		3	15		3		63	
	13		4	16		4		64	
	14		5	17		5		65	
	15		6	18		6		66	
*1	10	4	1	19	*1	10	12	1	67
	11		2	20		2		68	
	12		3	21		3		69	
	13		4	22		4		70	
	14		5	23		5		71	
	15		6	24		6		72	
*1	10	5	1	25	*1	10	13	1	73
	11		2	26		2		74	
	12		3	27		3		75	
	13		4	28		4		76	
	14		5	29		5		77	
	15		6	30		6		78	
*1	10	6	1	31	*1	10	14	1	79
	11		2	32		2		80	
	12		3	33		3		81	
	13		4	34		4		82	
	14		5	35		5		83	
	15		6	36		6		84	
*1	10	7	1	37	*1	10	15	1	85
	11		2	38		2		86	
	12		3	39		3		87	
	13		4	40		4		88	
	14		5	41		5		89	
	15		6	42		6		90	
*1	10	8	1	43	*1	10	16	1	91
	11		2	44		2		92	
	12		3	45		3		93	
	13		4	46		4		94	
	14		5	47		5		95	
	15		6	48		6		96	



*1) different possibilities of field device connections
for further information see manuals of 91xx/xx-xx-xx

We reserve the right to make alterations to the technical data, weights, dimensions, designs and products available without notice.
The illustration cannot be considered binding.

**pac-Carrier
Type 9195 / 16H-XX0-01C**

- Signal types: AI / AO / DI / DO / HART
- pac-Carrier for 16 modules, up to 32 signals
- all ISpac isolators can be mounted
- Redundant power supply with fault signalization contact and exchangeable fuses
- Horizontal or vertical installation
- Simple installation on DIN rail or mounting plate
- Many labeling possibilities
- Fast and secure installation of the isolators without tools
- Comfortable exchange of the isolators with secured ejector mechanism
- Installation possible in Zone 2, Zone 22

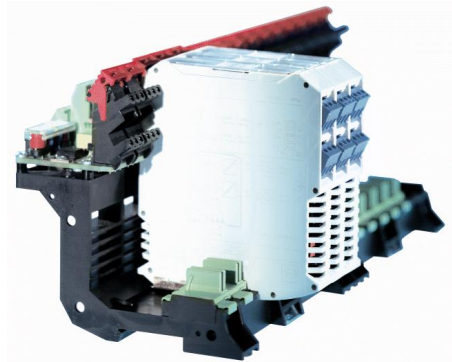

05179E00

Comfortable and simple integration of the Ex i / I.S. isolators ISpac. Flexible wiring possibilities on the system side with screw terminals.

System overview

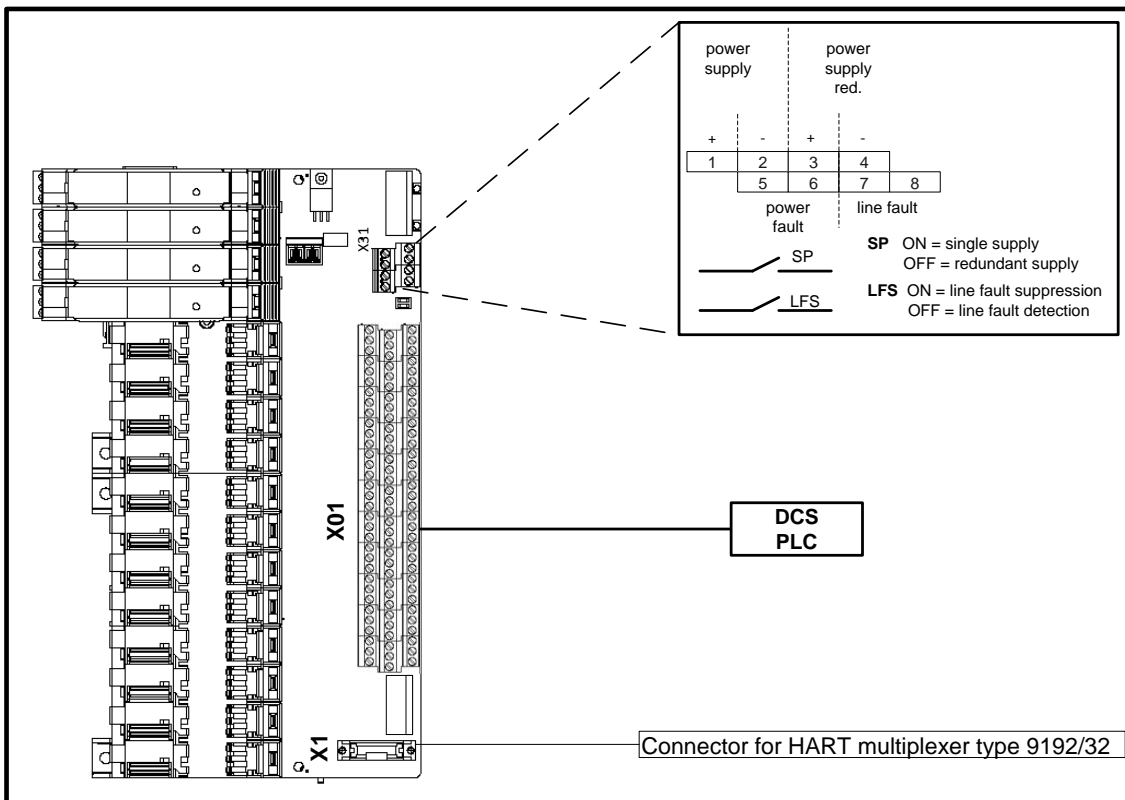

Selection table

Control system			pac-Carrier			
DCS manufacturer	DCS type	I/O-cards type	Slots	HART-MUX	Redundancy	Type
all	all	AI / AO / DI / DO / HART	16	9192/32	Yes	9195/16H-XX0-01C

Technical data

Certificates	BVS 03 E213 X
Explosion protection	⊕ II 3 G Ex nA nC II T4
Installation	In Zone 2, Zone 22 (non-conductible dust), Div. 2 and in the safe area
Power supply	(X31)
Nominal voltage U_N	24 V DC (19 V ... 31,2 V)
Redundant supply	yes, decoupled with diodes
Indication	2 LED green „PWR1“; „PWR2“
Fuse	2 x TR5; T 4,0 A; exchangeable, for primary and redundant supply
Polarity reversal protection	yes
Connection field devices	
Connection	at the terminals of the Ex i/I.S. isolators (see “signal loops”)
Number of channels	16
Connection automation system	(X01)
Connection	Customer specific cable
Number of channels	up to 32
Error messaging	(X31)
Power supply failure PF	Contact (35 V / 100 mA), closed in good conditions
Line fault LF (of IS pac modules)	Contact (35 V / 100 mA), closed in good conditions
Setting switch „SP“	Power failure message suppressed for redundant supply (single supply)
Setting switch „LFS“	Line fault message suppressed
Ambient conditions	
Ambient temperature	max. - 20 °C ... + 70 °C (see specification of the Ex i / I.S. isolators)
Storage temperature	- 40 °C ... + 80 °C
Relative humidity (no condensation)	≤95 %
Mechanical data	
Weight	approx. 320 g
Mounting type	on DIN rail (NS35 / 15, NS35 / 7.5) or mounting plate (4 x screw M6)
Mounting position	horizontal or vertical
Casing / Terminal protection class	IP 00 / IP 20
Casing material	PA 6.6
Fire protecting class (UL-94)	V0

Signal loops

The diagrams below show typical applications. Please refer to the connection list to get the entire connection scheme. Basic technical parameters of the ISpac isolating repeaters can be found at the end of this document. The detailed specifications can be downloaded at: www.ispac.info.

Transmitter supply unit (AI)
for 2-, 3-wire transmitter and mA sources
for 2-wire transmitter with HART

Alternative: Loop powered type 9162 and 9163

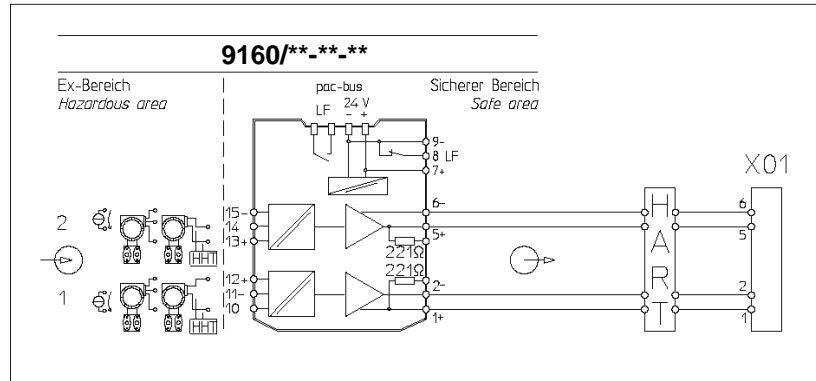

Isolating repeater (AO)
for control valves, i/p-converters or indicators
bi-directional HART communication

Alternative: Loop powered type 9167

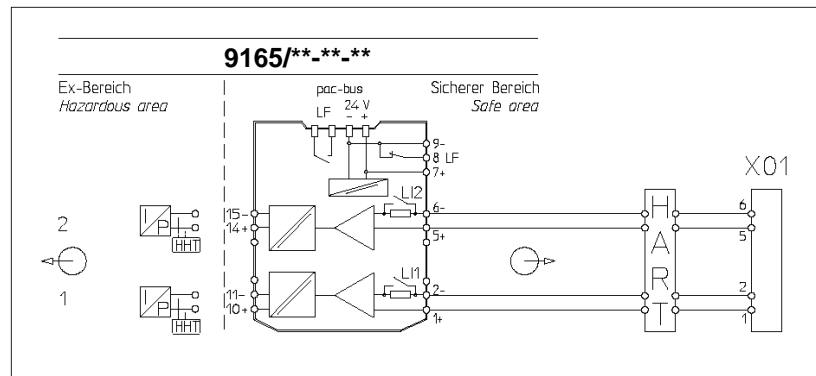

Accessories and Spare Parts

Designation	Illustration	Description	Order number
Non-Ex i Termination Module	 <p>06314E00</p>	The termination module is used to integrate non-Ex i field circuit into the system integration solution pac-Carrier type 9195. In such a way it enables a flexible mixture of Ex i and non-Ex i field circuits.	9191/20-00-50s

Dimension drawings (all dimensions in mm) - subject to alterations

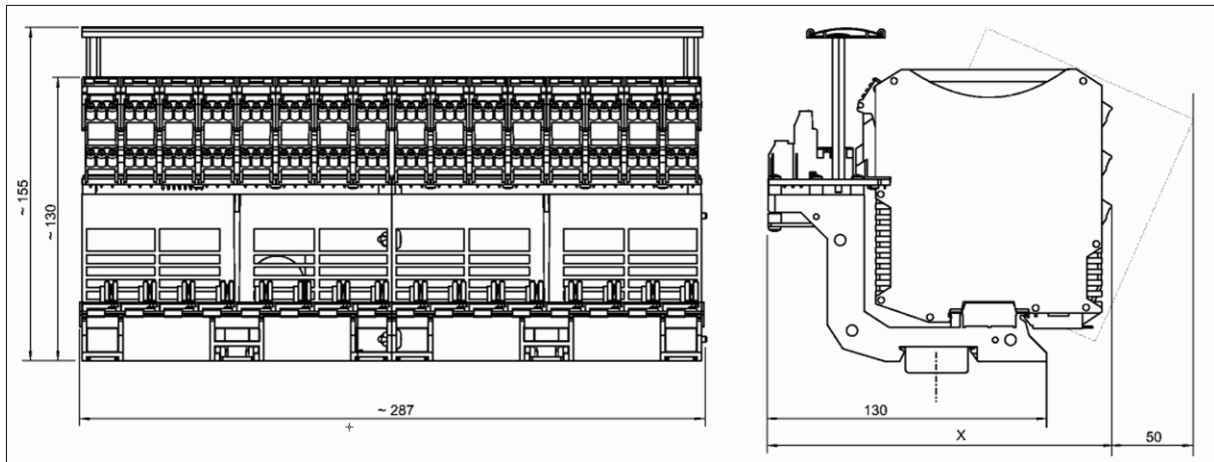

12472E00



	Dimension x
Screw terminals	176 mm
Cage clamp terminals	186 mm

Please note: In order to snap in the ISpac modules an extra space of approx. 50 mm is required. Please read the "ISpac engineering guideline" carefully before you start to engineer the enclosures with incorporated ISpac modules with or without pac-Carriers. The "ISpac engineering guideline" can be downloaded from: www.ispac.info.

Connection list

Connection to field devices (Ex i / I.S.)

notes	i.s terminal module	slot no.	terminal module	terminal X 01	notes	i.s terminal module	slot no.	terminal module	terminal X 01
*1	10	1	1	1	*1	10	9	1	49
	11		2	2		2		50	
	12		3	3		3		51	
	13		4	4		4		52	
	14		5	5		5		53	
	15		6	6		6		54	
*1	10	2	1	7	*1	10	10	1	55
	11		2	8		2		56	
	12		3	9		3		57	
	13		4	10		4		58	
	14		5	11		5		59	
	15		6	12		6		60	
*1	10	3	1	13	*1	10	11	1	61
	11		2	14		2		62	
	12		3	15		3		63	
	13		4	16		4		64	
	14		5	17		5		65	
	15		6	18		6		66	
*1	10	4	1	19	*1	10	12	1	67
	11		2	20		2		68	
	12		3	21		3		69	
	13		4	22		4		70	
	14		5	23		5		71	
	15		6	24		6		72	
*1	10	5	1	25	*1	10	13	1	73
	11		2	26		2		74	
	12		3	27		3		75	
	13		4	28		4		76	
	14		5	29		5		77	
	15		6	30		6		78	
*1	10	6	1	31	*1	10	14	1	79
	11		2	32		2		80	
	12		3	33		3		81	
	13		4	34		4		82	
	14		5	35		5		83	
	15		6	36		6		84	
*1	10	7	1	37	*1	10	15	1	85
	11		2	38		2		86	
	12		3	39		3		87	
	13		4	40		4		88	
	14		5	41		5		89	
	15		6	42		6		90	
*1	10	8	1	43	*1	10	16	1	91
	11		2	44		2		92	
	12		3	45		3		93	
	13		4	46		4		94	
	14		5	47		5		95	
	15		6	48		6		96	



*1) different possibilities of field device connections
for further information see manuals of 91xx/xx-xx-xx

We reserve the right to make alterations to the technical data, weights, dimensions, designs and products available without notice.
The illustration cannot be considered binding.

**pac-Carrier
Type 9195/08A-XX0-03A5**

- Signal types: 16 x AI or 16 x AO
- pac-Carrier for 8 modules, up to 16 signals
- ISpac isolator 9160/23-10-11, 9165/26-11-11 and 9182/20-59-11 can be used
- Customized system cable type 9195/C-007 to automation systems
- Redundant power supply with message contact and exchangeable fuses
- Horizontal or vertical installation
- Simple installation on DIN rail or mounting plate
- Many labeling possibilities
- Fast and secure installation of the isolators without tools
- Comfortable exchange of the isolators with secured ejector mechanism
- Installation possible in Zone 2, Zone 22 (non conductible dust) and Div. 2

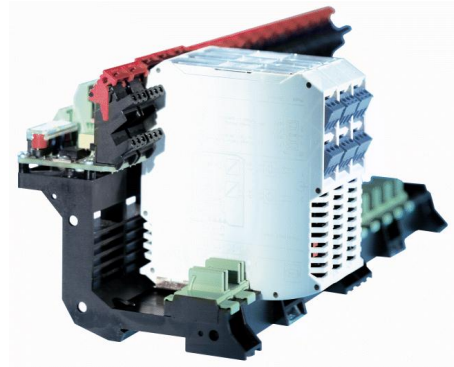

05179E00

Comfortable and simple integration of the Ex i / I.S. isolators ISpac. Flexible wiring possibilities on the system side with screw terminals.



System overview

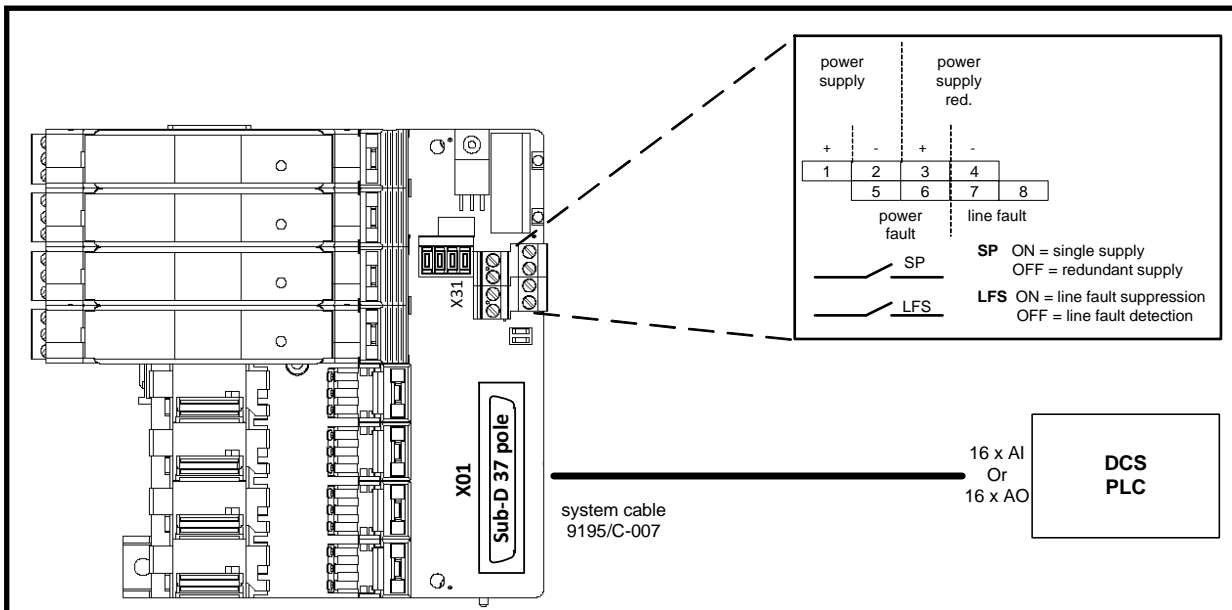

Selection table					
Control system			pac-Carrier		
DCS manufacturer	DCS type	Signal type	Slots	Stahl Cable type	Type
ALL	ALL	16 x AI	8	9195/C-007	9195/08A-XX0-03A5
		16 x AO			
Technical data					
Certificates		BVS 03 ATEX E213 X			
Explosion protection		⊕ II 3 G Ex nA nC II T4			
Installation		In Zone 2, Zone 22 (non conductible dust), Div. 2 and in the safe area			
Power supply		(X31)			
Nominal voltage U _N		24 V DC (19 V ... 31,2 V)			
Redundant supply		yes, decoupled with diodes			
Indication		2 LED green „PWR1“; „PWR2“			
Fuse		2 x TR5; T 2,0 A; exchangeable, for primary and redundant supply			
Polarity reversal protection		yes			
Connection field devices					
Connection		at the terminals of the I.S. isolators (see “signal loops”)			
Number of channels		16			
Connection automation system		(X01)			
Connection		plug Sub-D 37 pole for 9195/C-007			
Number of channels		up to 16			
Error messaging		(X31)			
Power supply failure PF		Contact (35 V / 100 mA), closed in good conditions			
Line fault LF (of ISpac modules)		Contact (35 V / 100 mA), closed in good conditions			
Setting switch „SP“		Power failure message suppressed for redundant supply (single supply)			
Setting switch „LFS“		Line fault message suppressed			
Ambient conditions					
Ambient temperature		max. - 20 °C ... + 70 °C (see specification of the I.S. isolators)			
Storage temperature		- 40 °C ... + 80 °C			
Relative humidity (no condensation)		≤95 %			
Mechanical data					
Weight		approx. 320 g			
Mounting type		on DIN rail (NS35 / 15, NS35 / 7.5) or mounting plate (4 x screw M6)			
Mounting position		horizontal or vertical			
Casing / Terminal protection class		IP 00 / IP 20			
Casing material		PA 6.6			
Fire protecting class (UL-94)		V0			



Signal loops

The diagrams below show typical applications. Please refer to the connection list to get the entire connection scheme. Basic technical parameters of the ISpac isolating repeaters can be found at the end of this document. The detailed specifications can be downloaded at: www.ispac.info.

Transmitter supply unit (AI)
for 2-, 3-wire transmitter and mA sources
for 2-wire transmitter with HART

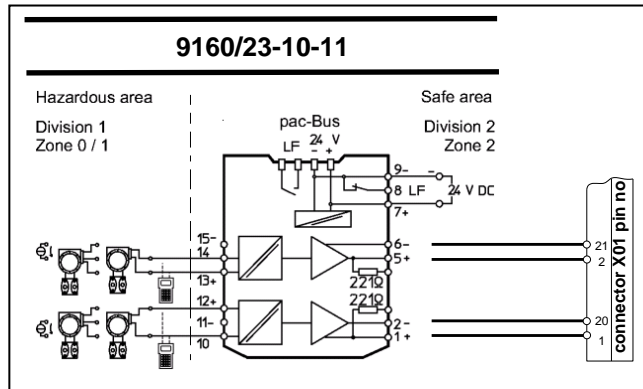

Isolating Repeater (AO)
for control valves, i/p-converters or indicators
bi-directional HART communication

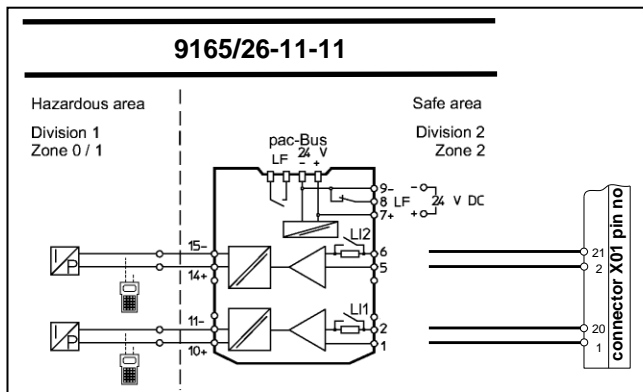

Temperature transmitter (AI)
for resistance thermometer, thermocouple and RTD
(Configuration by means of DIP Switches or
ISpac Wizard software)

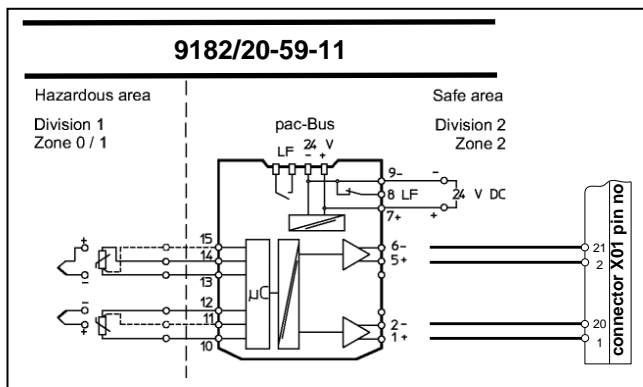

*) Suitable for 4-wire (Pins: 10, 11, 12, and 14).
The connection of two sensors in 4-wire scheme requires an additional external terminal.



Accessories and Spare Parts

Designation	Illustration	Description	Order number
Non-Ex i Termination Module	 <p>06314E00</p>	The termination module is used to integrate non-Ex i field circuit into the system integration solution pac-Carrier type 9195. In such a way it enables a flexible mixture of Ex i and non-Ex i field circuits.	9191/20-00-50s
System cable		Customized system cable type 9195/C-007 with Sub-D 37 system cable 40 x 0,35 (AWG 24) grey	9195/C-007

Dimension drawings (all dimensions in mm) - subject to alterations

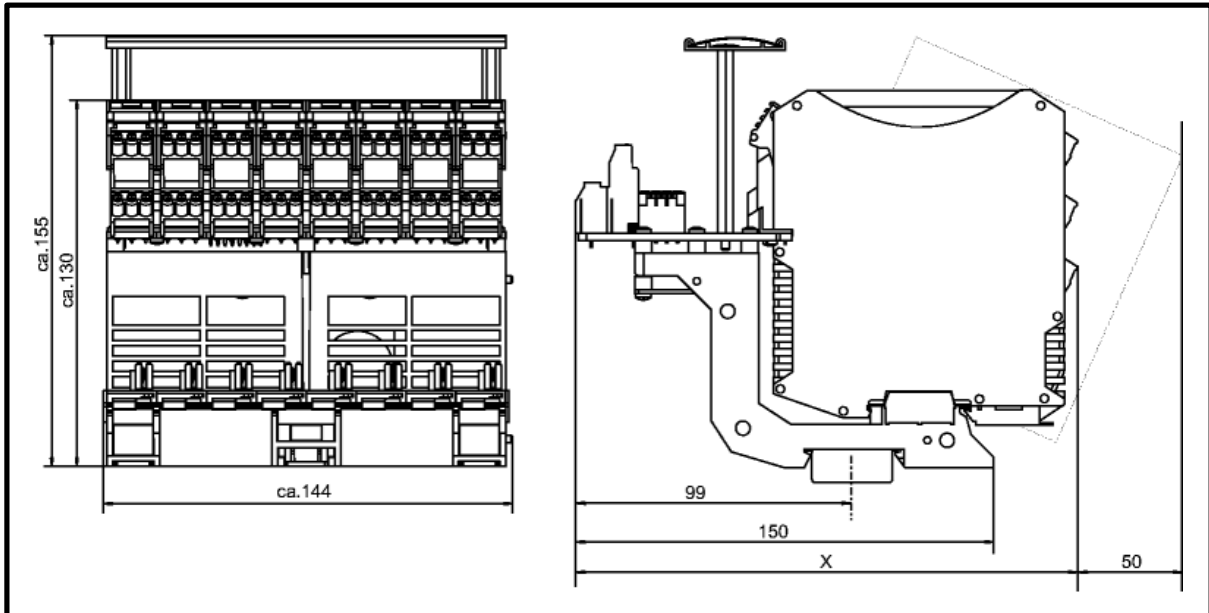

12472E00

	Dimension x
Screw terminals	176 mm
Cage clamp terminals	186 mm

Please note: In order to snap in the ISpac modules an extra space of approx. 50 mm is required. Please read the "ISpac engineering guideline" carefully before you start to engineer the enclosures with incorporated ISpac modules with or without pac-Carriers. The "ISpac engineering guideline" can be downloaded from: www.ispac.info.



Connection list

channel	terminal I.S.		carrier slot	X01		Cable 9195/C-007 color code	Input pin no.	
	modules			(Sub-D 37)				
	AI: 9160 AO: 9165 AI: 9182	polarity		pin no.	Polarity			
1	1*)	+	1	1	+	White		
		-		20	-	Brown		
1*)	+	2		+	Green			
	-	21		-	Yellow			
3	1*)	+		2	3	+	Gray	
		-			22	-	Pink	
4	1*)	+			4	+	Blue	
		-			23	-	Red	
5	1*)	+	3		5	+	Black	
		-			24	-	Purple	
6	1*)	+			6	+	gray-pink	
		-			25	-	red-blue	
7	1*)	+		4	7	+	white-green	
		-			26	-	brown-green	
8	1*)	+			8	+	white-yellow	
		-			27	-	yellow-brown	
9	1*)	+	5		9	+	white-gray	
		-			28	-	gray-brown	
10	1*)	+			10	+	white-pink	
		-			29	-	pink-brown	
11	1*)	+		6	11	+	white-blue	
		-			30	-	brown-blue	
12	1*)	+			12	+	white-red	
		-			31	-	brown-red	
13	1*)	+	7		13	+	white-black	
		-			32	-	brown-black	
14	1*)	+			14	+	gray-green	
		-			33	-	yellow-gray	
15	1*)	+		8	15	+	pink-green	
		-			34	-	yellow-pink	
16	1*)	+			16	+	green-blue	
		-			35	-	yellow-blue	
not used					17		green-red	
not used					36		yellow-red	
not used					18		green-black	
not used					37		yellow-black	
not used				19		gray-blue		
not used				38		pink-blue		
not used				39		gray-red		
not used				40		pink-red		

*) different possibilities of field device connections; for further information see: manual of:
9160/23-10-11, 9165/26-11-11 and 9182/20-59-11

We reserve the right to make alterations to the technical data, weights, dimensions, designs and products available without notice.
The illustration cannot be considered binding



**pac-Carrier
Type 9195/16A-XX0-03B3**

- Signal types: 32 x DI or 32 x DO
- pac-Carrier for 16 modules, up to 32 signals
- ISpac isolator 9170/20-10-11, 9175/20-1X-11 and 9176/20-1X-00 can be used
- Customized system cable type 9195/C-009 to automation systems
- Redundant power supply with message contact and exchangeable fuses
- Horizontal or vertical installation
- Simple installation on DIN rail or mounting plate
- Many labeling possibilities
- Fast and secure installation of the isolators without tools
- Comfortable exchange of the isolators with secured ejector mechanism
- Installation possible in Zone 2, Zone 22 (non conductible dust) and Div. 2

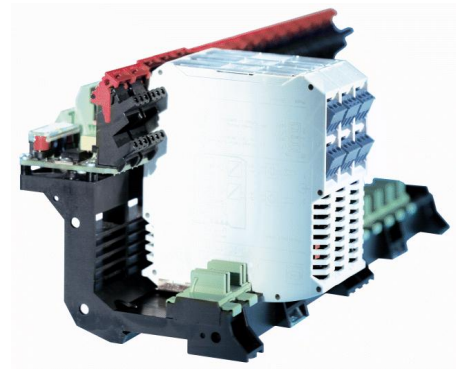

05179E00

Comfortable and simple integration of the Ex i / I.S. isolators ISpac. Flexible wiring possibilities on the system side with screw terminals.

System overview

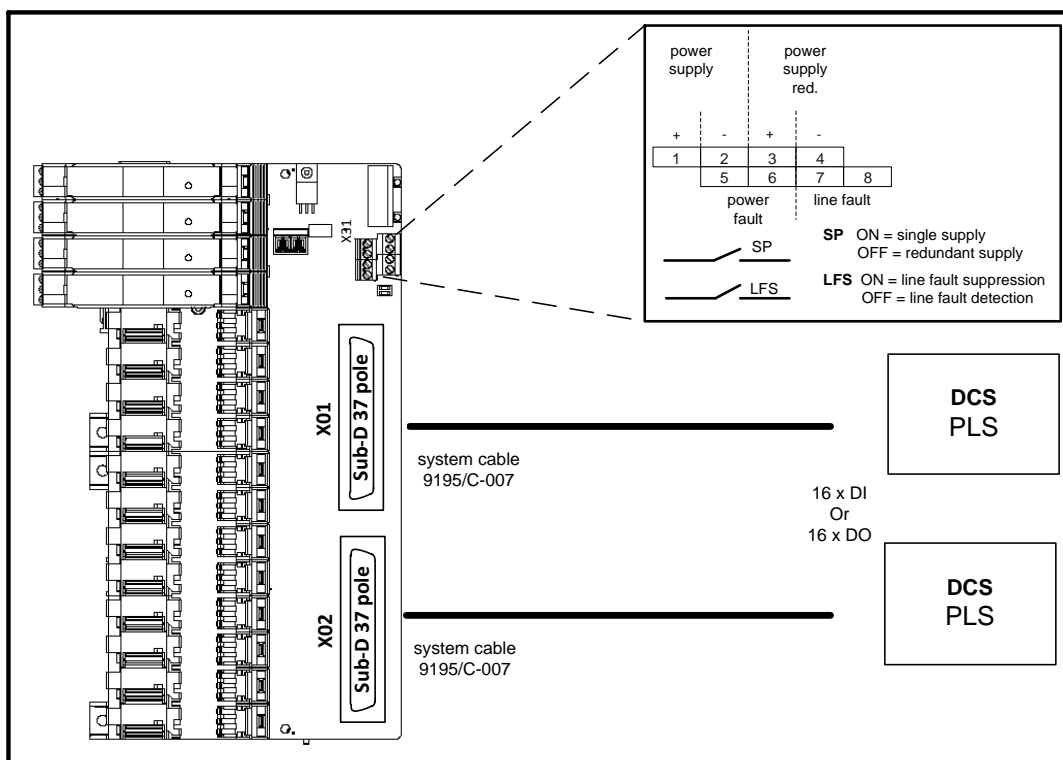

Selection table					
Control system			pac-Carrier		
DCS manufacturer	DCS type	Signal type	Slots	Stahl Cable type	Type
ALL	ALL	32 x DI	16	9195/C-007	9195/16A-XX0-03B3
		32 x DO			
Technical data					
Certificates		BVS 03 ATEX E213 X			
Explosion protection		⊕ II 3 G Ex nA nC II T4			
Installation		In Zone 2, Zone 22 (non conductible dust), Div. 2 and in the safe area			
Power supply		(X31)			
Nominal voltage U_N		24 V DC (19 V ... 31,2 V)			
Redundant supply		yes, decoupled with diodes			
Indication		2 LED green „PWR1“; „PWR2“			
Fuse		2 x TR5; T 2,0 A; exchangeable, for primary and redundant supply			
Polarity reversal protection		yes			
Connection field devices					
Connection		at the terminals of the I.S. isolators (see "signal loops")			
Number of channels		32			
Connection automation system		(X01)			
Connection		plug Sub-D 37 pole for 9195/C-007			
Number of channels		up to 16			
Connection automation system		(X02)			
Connection		plug Sub-D 37 pole for 9195/C-009			
Number of channels		up to 16			
Error messaging		(X31)			
Power supply failure PF		Contact (35 V / 100 mA), closed in good conditions			
Line fault LF (of ISpac modules)		Contact (35 V / 100 mA), closed in good conditions			
Setting switch „SP“		Power failure message suppressed for redundant supply (single supply)			
Setting switch „LFS“		Line fault message suppressed			
Ambient conditions					
Ambient temperature		max. - 20 °C ... + 70 °C (see specification of the I.S. isolators)			
Storage temperature		- 40 °C ... + 80 °C			
Relative humidity (no condensation)		≤95 %			
Mechanical data					
Weight		approx. 320 g			
Mounting type		on DIN rail (NS35 / 15, NS35 / 7.5) or mounting plate (4 x screw M6)			
Mounting position		horizontal or vertical			
Casing / Terminal protection class		IP 00 / IP 20			
Casing material		PA 6.6			
Fire protecting class (UL-94)		V0			

Signal loops

The diagrams below show typical applications. Please refer to the connection list to get the entire connection scheme. Basic technical parameters of the ISpac isolating repeaters can be found at the end of this document. The detailed specifications can be downloaded at: www.ispac.info.

Switching repeater (DI)

for NAMUR proximity switches and contacts
- relay output

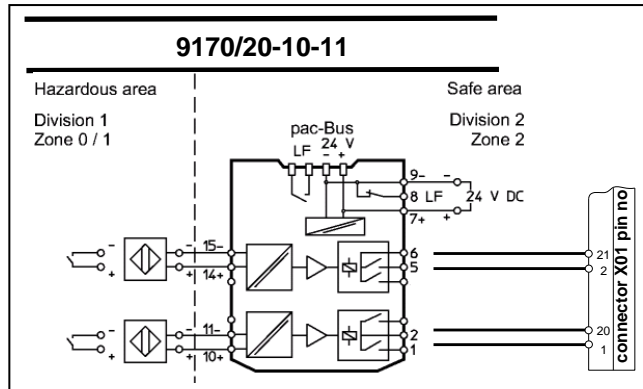

Digital output (DO)

for solenoid valves and indicators

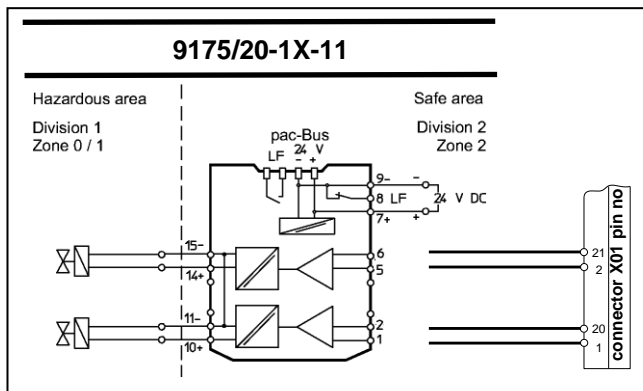

Digital output (DO)

for solenoid valves and indicators
- loop powered

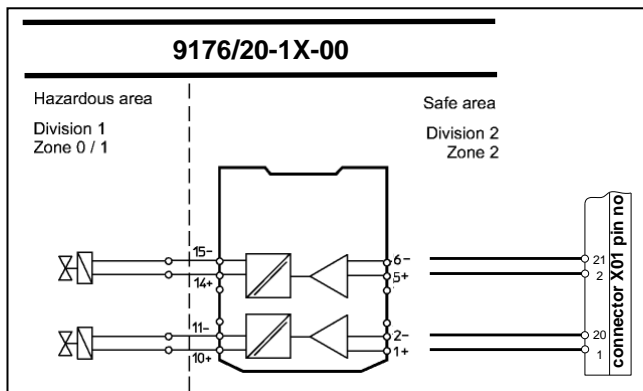

Accessories and Spare Parts

Designation	Illustration	Description	Order number
Non-Ex i Termination Module	 <p>06314E00</p>	The termination module is used to integrate non-Ex i field circuit into the system integration solution pac-Carrier type 9195. In such a way it enables a flexible mixture of Ex i and non-Ex i field circuits.	9191/20-00-50s
System cable		Customized system cable type 9195/C-007 with Sub-D 37 system cable 40 x 0,35 (AWG 24) grey	9195/C-007

Dimension drawings (all dimensions in mm) - subject to alterations

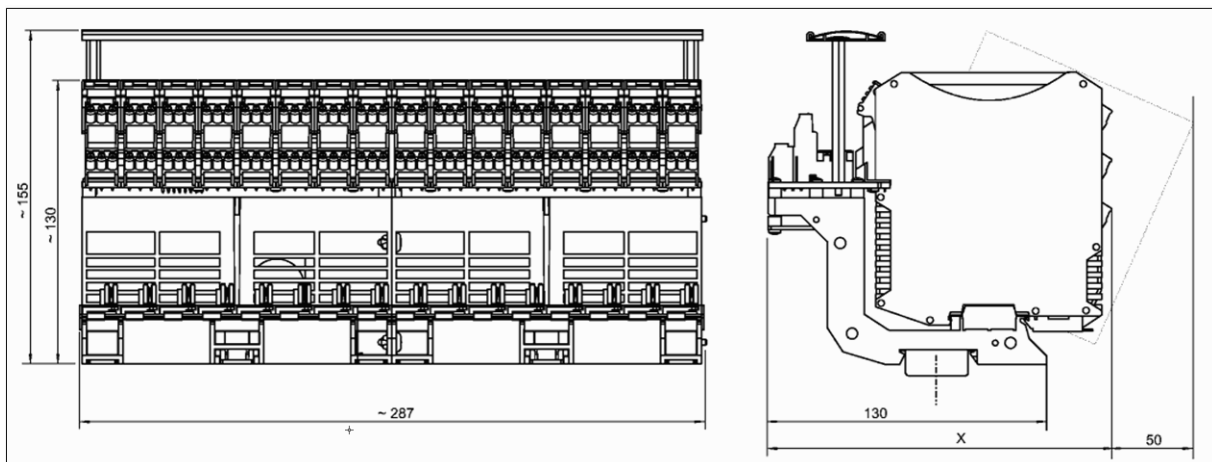

12472E00

	Dimension x
Screw terminals	176 mm
Cage clamp terminals	186 mm

Please note: In order to snap in the ISpac modules an extra space of approx. 50 mm is required. Please read the "ISpac engineering guideline" carefully before you start to engineer the enclosures with incorporated ISpac modules with or without pac-Carriers. The "ISpac engineering guideline" can be downloaded from: www.ispac.info.

Connection list

channel	terminal I.S. modules		carrier slot	X01 (Sub-D 37)		Cable 9195/C-007 color code	Input pin no.
	DI: 9170 DO: 9175 DO: 9176	polarity		pin no.	Polarity		
1	1*)	+	1	1	+	White	
		-		20	-	Brown	
2	1*)	+	1	2	+	Green	
		-		21	-	Yellow	
3	1*)	+	2	3	+	Gray	
		-		22	-	Pink	
4	1*)	+	2	4	+	Blue	
		-		23	-	Red	
5	1*)	+	3	5	+	Black	
		-		24	-	Purple	
6	1*)	+	3	6	+	gray-pink	
		-		25	-	red-blue	
7	1*)	+	4	7	+	white-green	
		-		26	-	brown-green	
8	1*)	+	4	8	+	white-yellow	
		-		27	-	yellow-brown	
9	1*)	+	5	9	+	white-gray	
		-		28	-	gray-brown	
10	1*)	+	5	10	+	white-pink	
		-		29	-	pink-brown	
11	1*)	+	6	11	+	white-blue	
		-		30	-	brown-blue	
12	1*)	+	6	12	+	white-red	
		-		31	-	brown-red	
13	1*)	+	7	13	+	white-black	
		-		32	-	brown-black	
14	1*)	+	7	14	+	gray-green	
		-		33	-	yellow-gray	
15	1*)	+	8	15	+	pink-green	
		-		34	-	yellow-pink	
16	1*)	+	8	16	+	green-blue	
		-		35	-	yellow-blue	
	not used			17		green-red	
	not used			36		yellow-red	
	not used			18		green-black	
	not used			37		yellow-black	
	not used			19		gray-blue	
	not used			38		pink-blue	
	not used			39		gray-red	
	not used			40		pink-red	

*) different possibilities of field device connections;
for further information see: manual of:
9170/20-10-11, 9175/20-1X-11 and 9176/20-1X-00

We reserve the right to make alterations to the technical data,
weights, dimensions, designs and products available without
notice. The illustration cannot be considered binding



Connection list

channel	terminal I.S.		carrier slot	X02 (Sub-D 37)		Cable 9195/C-007 color code	Input pin no.	
	modules			pin no.	Polarity			
	DI: 9170 DO: 9175 DO: 9176	polarity						
17	1*)	+	1	1	+	White		
		-		20	-	Brown		
18	1*)	+		2	+	Green		
		-		21	-	Yellow		
19	1*)	+		2	3	+	Gray	
		-			22	-	Pink	
20	1*)	+			4	+	Blue	
		-			23	-	Red	
21	1*)	+	3	5	+	Black		
		-		24	-	Purple		
22	1*)	+		6	+	gray-pink		
		-		25	-	red-blue		
23	1*)	+	4	7	+	white-green		
		-		26	-	brown-green		
24	1*)	+		8	+	white-yellow		
		-		27	-	yellow-brown		
25	1*)	+	5	9	+	white-gray		
		-		28	-	gray-brown		
26	1*)	+		10	+	white-pink		
		-		29	-	pink-brown		
27	1*)	+	6	11	+	white-blue		
		-		30	-	brown-blue		
28	1*)	+		12	+	white-red		
		-		31	-	brown-red		
29	1*)	+	7	13	+	white-black		
		-		32	-	brown-black		
30	1*)	+		14	+	gray-green		
		-		33	-	yellow-gray		
31	1*)	+	8	15	+	pink-green		
		-		34	-	yellow-pink		
32	1*)	+		16	+	green-blue		
		-		35	-	yellow-blue		
not used				17		green-red		
not used				36		yellow-red		
not used				18		green-black		
not used				37		yellow-black		
not used				19		gray-blue		
not used				38		pink-blue		
not used				39		gray-red		
not used				40		pink-red		

*) different possibilities of field device connections;
for further information see: manual of:
9170/20-10-11, 9175/20-1X-11 and 9176/20-1X-00

We reserve the right to make alterations to the technical data,
weights, dimensions, designs and products available without
notice. The illustration cannot be considered binding

Notes:



A small logo consisting of the word 'STAH' in white capital letters inside a black octagonal border.A larger logo consisting of the word 'STAH' in white capital letters inside a blue octagonal border.**R. STAHL Schaltgeräte GmbH**

Am Bahnhof 30, D-74638 Waldenburg, Germany

Telefon +49 7942 943-0

Telefax +49 7942 943-4333

E-Mail: info.ex@stahl.deInternet: <http://www.stahl.de>

S – EG / EP – 9195 – 4 – en – 07 / 2011